

Retrorefletor Triangular 8939

Com alta taxa de retroreflexão atendem de forma plena as exigências normativas garantindo segurança e visibilidade.

- Solução Compacta;
- Maior Visibilidade
- Produzido no Brasil;

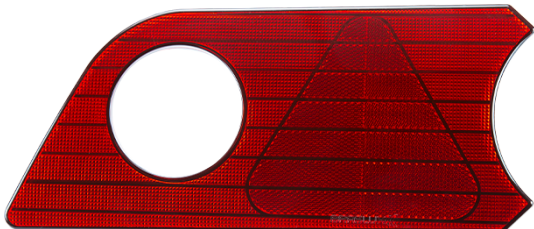

Aplicações sugeridas



Imagem meramente ilustrativa

Dados técnicos:

Material da Lente:	-
Material Da Carcaça:	-
Material do Refletor:	-
Torque Máximo:	1,5 N.m
Peso:	0,202 kg
Iluminação:	LED

Homologações:

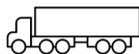

Homologado
Contran 970

Aprovações:



Patenteado Braslux



1500h (carcaça)
1500h (lente)



-40°C a 50°C

Código	Lado	Fixação	Cor da Lente
8939.00.302	Direito	Traseira - diâm 5	Rubi
8939.01.302	Esquerdo	Traseira - diâm 5	Rubi

Para mais informações consultar o site www.braslux.com

Desenho técnico:

Unidade de medida em mm

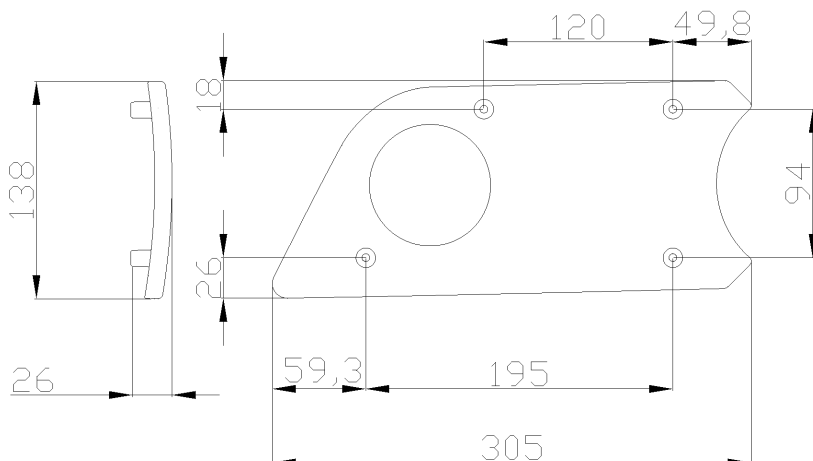

Triangle Retroreflector 8939

High retroreflection rate fully meets regulatory requirements ensuring safety and visibility.

- Compact Solution;
- Enhanced Visibility
- Made in Brazil;



Suggested Applications

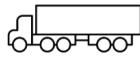

Illustrative Image

Technical Data:

Lens Material:	-
Housing Material:	-
Reflector Material:	-
Maximum Torque:	1,5 N.m
Weight:	0,202 kg
Illumination:	LED

Certificate:



Homologated
Contran 970

Approvals:



Braslux Patented



1500h (housing)
1500h (lente)



-40°C a 50°C

Code	Side	Fix	Lens Color
8939.00.302	Right	Rear - diam 5	Ruby
8939.01.302	Left	Rear - diam 5	Ruby

Para mais informações consultar o site www.braslux.com

Technical Drawing:

Unit of measure in millimeters

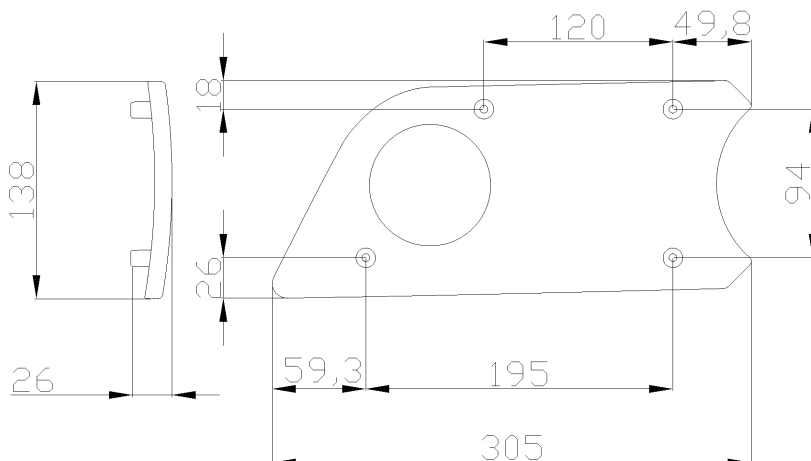

Retroreflector Triangular

8939

Con alta tasa de retroreflexión, cumplen plenamente con las exigencias normativas garantizando seguridad y visibilidad.

- Solución Compacta;
- Mayor Visibilidad
- Producido en Brasil;



Aplicaciones Sugeridas



Imagen Puramente Ilustrativa

Datos Técnicos:

Material de la Lente:	-
Material de la Carcasa:	-
Material del Reflector:	-
Par Máximo:	1,5 N.m
Peso:	0,202 kg
Iluminación:	LED

Certificado:

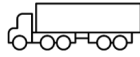

Homologado
Contran 970

Aprobaciones:



Patentado



1500h (cuerpo)
1500h (lente)



-40°C a 50°C

Código	Lado	Fijación	Color de Lente
8939.00.302	Derecho	Trasera - diám 5	Rubí
8939.01.302	Izquierdo	Trasera - diám 5	Rubí

Para mais informações consultar o site www.braslux.com

Diseño Técnico:

Unidad de medida en milímetros

