

## Lanterna Interna Lumi Touch 8073

Disponível um amplo leque de soluções para distintas finalidades, com elevada eficiência e confiança garantida.

- Solução Compacta;
- Original Braslux;
- Maior Visibilidade



### Aplicações sugeridas



Imagem meramente ilustrativa

### Dados técnicos:

<b>Material da Lente:</b>	PMMA
<b>Material Da Carcaça:</b>	ABS
<b>Material do Refletor:</b>	-
<b>Torque Máximo:</b>	1,5 N.m
<b>Peso:</b>	0,0555 kg
<b>Iluminação:</b>	LED

### Homologações:

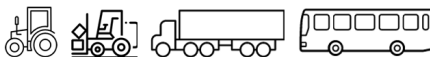

Homologado  
Contran 970

### Aprovações:



Patenteado Braslux



1500h (carcaça)  
1500h (lente)



Sobretensão



-40°C a 50°C

Código	Tensão	Conexão Elétrica	Fixação	Cor da Lente	Potência
8073.76.305	12/24V	Faston 1 via	Frontal	Cristal	12V - 3,4W/24V - 3,4W
8073.78.305	12/24V	Saída de fios	Frontal	Cristal	12V - 3,4W/24V - 3,4W

Para mais informações consultar o site [www.braslux.com](http://www.braslux.com)

### Desenho técnico:

Unidade de medida em mm

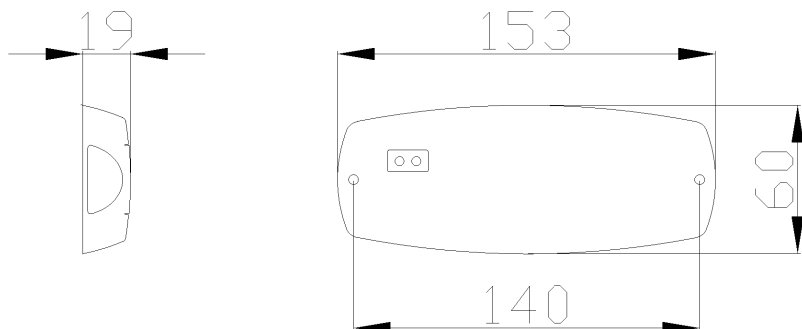

# Lumi Touch Interior Light 8073

A wide range of solutions is available for various purposes, offering high efficiency and guaranteed reliability.

- Compact Solution;
- Enhanced Visibility
- Braslux Original;



## Suggested Applications

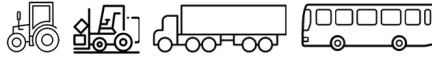

Illustrative Image

### Technical Data:

<b>Lens Material:</b>	PMMA
<b>Housing Material:</b>	ABS
<b>Reflector Material:</b>	-
<b>Maximum Torque:</b>	1,5 N.m
<b>Weight:</b>	0,0555 kg
<b>Illumination:</b>	LED

### Certificate:



Homologated  
Contran 970

### Approvals:



Braslux Patented



1500h (housing)  
1500h (lente)



Overvoltage



-40°C a 50°C

Code	Voltage	Connector	Fix	Lens Color	Power
8073.76.305	12/24V	Faston 1-way	Front	Crystal	12V - 3,4W/24V - 3,4W
8073.78.305	12/24V	Wire output	Front	Crystal	12V - 3,4W/24V - 3,4W

Para mais informações consultar o site [www.braslux.com](http://www.braslux.com)

### Technical Drawing:

Unit of measure in millimeters

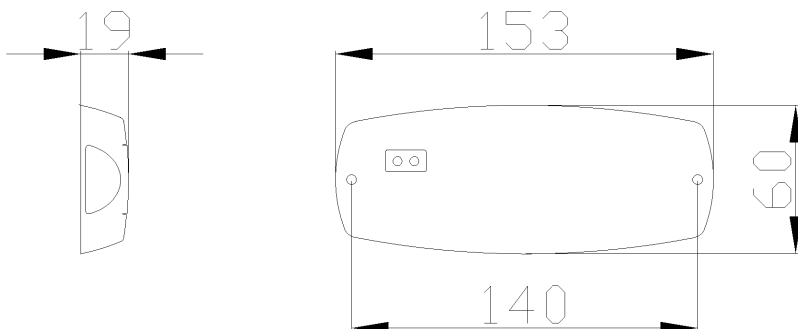

# Luz Interna Lumi Touch 8073

Está disponible una amplia variedad de soluciones para diversos fines, con alta eficiencia y confiabilidad garantizada.

- Solución Compacta;
- Mayor Visibilidad
- Original Braslux;



## Aplicaciones Sugeridas



Imagen Puramente Ilustrativa

### Datos Técnicos:

<b>Material de la Lente:</b>	PMMA
<b>Material de la Carcasa:</b>	ABS
<b>Material del Reflector:</b>	-
<b>Par Máximo:</b>	1,5 N.m
<b>Peso:</b>	0,0555 kg
<b>Iluminación:</b>	LED

### Certificado:

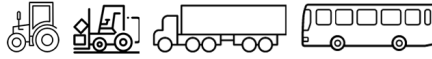

Homologado  
Contran 970

### Aprobaciones:



Patentado



1500h (cuerpo)  
1500h (lente)



Sobretensión



-40°C a 50°C

Código	Tensión	Conector	Fijación	Color de Lente	Fuerza
8073.76.305	12/24V	Faston 1 vía	Frontal	Cristal	12V - 3,4W/24V - 3,4W
8073.78.305	12/24V	Salida de cable	Frontal	Cristal	12V - 3,4W/24V - 3,4W

Para mais informações consultar o site [www.braslux.com](http://www.braslux.com)

### Diseño Técnico:

Unidad de medida en milímetros

