

Lanterna Interna Dicroica Ø85mm 8037

Ampla gama de soluções para as mais diversas aplicações, com alto grau de eficiência e confiabilidade.

- Solução Compacta;
- Maior Visibilidade
- Produzido no Brasil;



Aplicações sugeridas



Imagem meramente ilustrativa

Dados técnicos:

Material da Lente:	PMMA
Material Da Carcaça:	ABS
Material do Refletor:	-
Torque Máximo:	-
Peso:	0,042 kg
Iluminação:	LED

Homologações:

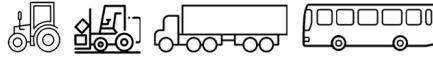

Homologado
Contran 970

Aprovações:



IP40



500h (carcaça)
500h (lente)



-40°C a 50°C

Código	Tensão	Conexão Elétrica	Fixação	Cor da Lente	Potência
8037.71.305	12/24V	Faston 2 vias	Embutir	Cristal	12V - 1,25W/24V - 1,25W
8037.91.305	12/24V	Faston 2 vias	Embutir	Cristal	12V - 1,7W/24V - 1,7W

Para mais informações consultar o site www.braslux.com

Desenho técnico:

Unidade de medida em mm

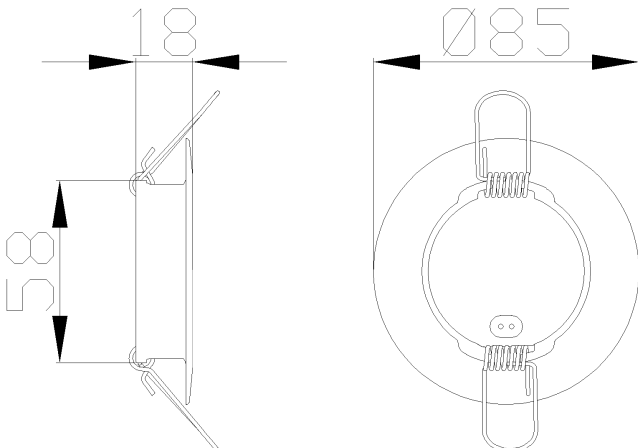

Ø85mm Interior Dome Light 8037

Wide solutions range for various applications, with high efficiency and reliability.

- Compact Solution;
- Made in Brazil;
- Enhanced Visibility



Suggested Applications

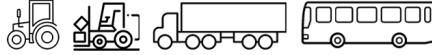

Illustrative Image

Technical Data:

Lens Material:	PMMA
Housing Material:	ABS
Reflector Material:	-
Maximum Torque:	-
Weight:	0,042 kg
Illumination:	LED

Certificate:



Homologated
Contran 970

Approvals:



IP40



500h (housing)
500h (lente)



-40°C a 50°C

Code	Voltage	Connector	Fix	Lens Color	Power
8037.71.305	12/24V	Faston 2-way	Recessed	Crystal	12V - 1,25W 24V - 1,25W
8037.91.305	12/24V	Faston 2-way	Recessed	Crystal	12V - 1,7W 24V - 1,7W

Para mais informações consultar o site www.braslux.com

Technical Drawing:

Unit of measure in millimeters

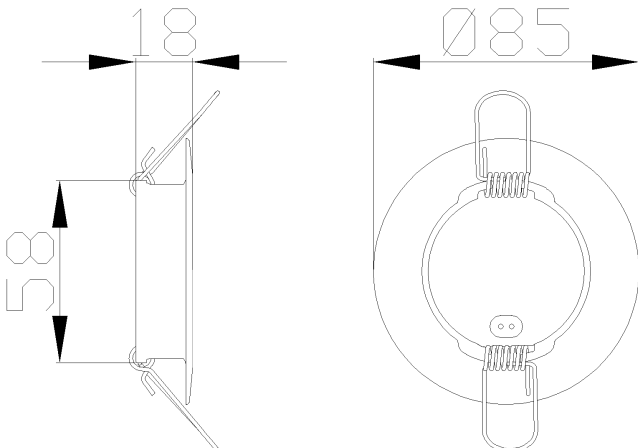

Luz Interna Dicroica Ø85mm 8037

Amplia gama de soluciones para las más diversas aplicaciones, con alto grado de eficiencia y confiabilidad.

- Solución Compacta;
- Mayor Visibilidad
- Producido en Brasil;



Aplicaciones Sugeridas



Imagen Puramente Ilustrativa

Datos Técnicos:

Material de la Lente:	PMMA
Material de la Carcasa:	ABS
Material del Reflector:	-
Par Máximo:	-
Peso:	0,042 kg
Iluminación:	LED

Certificado:

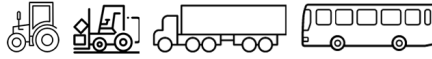

Homologado
Contran 970

Aprobaciones:



IP40



500h (cuerpo)
500h (lente)



-40°C a 50°C

Código	Tensión	Conector	Fijación	Color de Lente	Fuerza
8037.71.305	12/24V	Faston 2 vías	Empotrado	Cristal	12V - 1,25W 24V - 1,25W
8037.91.305	12/24V	Faston 2 vías	Empotrado	Cristal	12V - 1,7W 24V - 1,7W

Para mais informações consultar o site www.braslux.com

Diseño Técnico:

Unidad de medida en milímetros

