

Lanterna Ø110mm com Aba 8049

Com tamanho compacto e múltiplas configurações de 1 a 4 funções, proporcionam versatilidade no design para diferentes aplicações.

- Solução Compacta;
- Fácil Instalação
- Original Braslux;



Aplicações sugeridas



Imagem meramente ilustrativa

Dados técnicos:

Material da Lente:	PMMA
Material Da Carcaça:	ABS
Material do Refletor:	ABS
Torque Máximo:	1,5 N.m
Peso:	0,2315 kg
Iluminação:	LED

Homologações:

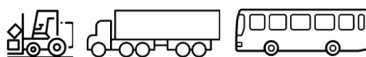

Homologado
Contran 970

Aprovações:



Patenteado Braslux



IP6K7



1500h (carcaça)
1500h (lente)



Sobretensão



-40°C a 50°C

Código	Lado	Tensão	Conexão Elétrica	Fixação	Funções	Cor da Lente	Potência Posição	Potência Direcional	Potência Freio	Potência Ré	Potência Nebliina
8049.72.301	N/A	24V	Faston 6,3 mm	Frontal	Direcional	Âmbar	-	12V - 3,6W24V - 2,9W	-	-	-
8049.72.305	N/A	24V	Faston 6,3 mm	Frontal	Ré	Cristal	-	-	-	12V - 3,6W24V - 2,9W	-

Para mais informações consultar o site www.braslux.com

Desenho técnico:

Unidade de medida em mm

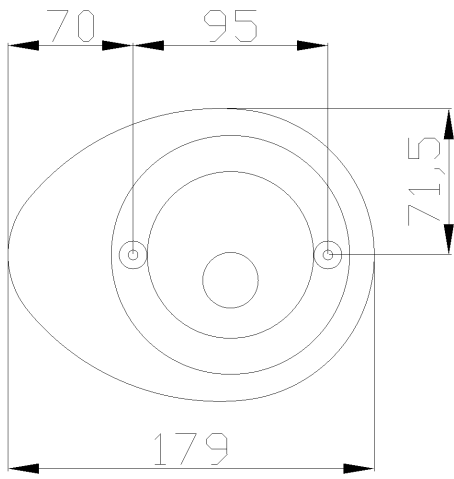

Ø100mm Rear Light with Flange 8049

With compact size and multiple configurations from 1 to 4 functions, it provides design versatility for different applications.

- Compact Solution;
- Easy Installation
- Braslux Original;



Suggested Applications

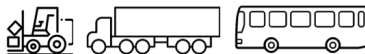

Illustrative Image

Technical Data:

Lens Material:	PMMA
Housing Material:	ABS
Reflector Material:	ABS
Maximum Torque:	1,5 N.m
Weight:	0,2315 kg
Illumination:	LED

Certificate:



Homologated
Contran 970

Approvals:



Braslux Patented



IP6K7



1500h (housing)
1500h (lente)



Overvoltage



-40°C a 50°C

Code	Side	Voltage	Connector	Fix	Functions	Lens Color	Position Light Power	Directional Light Power	Brake Light Power	Rear Light Power	Fog Light Power
8049.72.301	N/A	24V	Faston 6,3 mm	Front	Directional	Amber	-	12V - 3,6W24V - 2,9W	-	-	-
8049.72.305	N/A	24V	Faston 6,3 mm	Front	Reverse	Crystal	-	-	-	12V - 3,6W24V - 2,9W	-

Para mais informações consultar o site www.braslux.com

Technical Drawing:

Unit of measure in millimeters

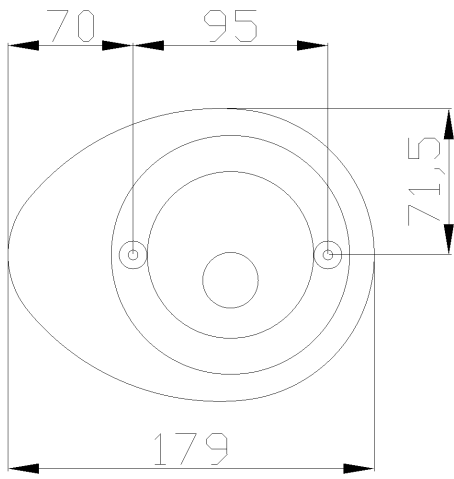

Luz Trasera Ø100mm con Solapa 8049

Con tamaño compacto y múltiples configuraciones de 1 a 4 funciones, proporcionan versatilidad de diseño para diferentes aplicaciones.

- Solución Compacta;
- Original Braslux;
- Instalación Fácil



Aplicaciones Sugeridas



Imagen Puramente Ilustrativa

Datos Técnicos:

Material de la Lente:	PMMA
Material de la Carcasa:	ABS
Material del Reflector:	ABS
Par Máximo:	1,5 N.m
Peso:	0,2315 kg
Iluminación:	LED

Certificado:

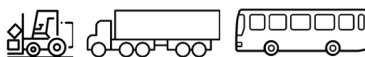

Homologado
Contran 970

Aprobaciones:



Patentado



IP6K7



1500h (cuerpo)
1500h (lente)



Sobretensión



-40°C a 50°C

Código	Lado	Tensión	Conector	Fijación	Funciones	Color de Lente	Potencia de la Luz de Posición	Potencia de la Luz Direccional	Potencia de la Luz de Freno	Potencia de Luz de Marcha Atrás	Potencia Luz Antiniebla
8049.72.301	N/A	24V	Faston 6,3 mm	Frontal	Direccional	Ámbar	-	12V - 3,6W/24V - 2,9W	-	-	-
8049.72.305	N/A	24V	Faston 6,3 mm	Frontal	Reversa	Cristal	-	-	-	12V - 3,6W/24V - 2,9W	-

Para mais informações consultar o site www.braslux.com

Diseño Técnico:

Unidad de medida en milímetros

